

D FENDERS

Extruded from natural rubber, these fenders are ideal for handling medium loadings and are equally as appropriate to truck loading bays as they are to wharf/vessel protection. Available in a range of cross-sectional sizes, - refer to profiles below and can be bolted, strapped or sleeve mounted in position.

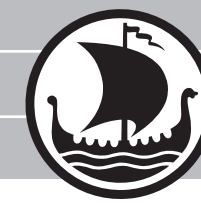

Profiles are shown approximately one quarter full size.

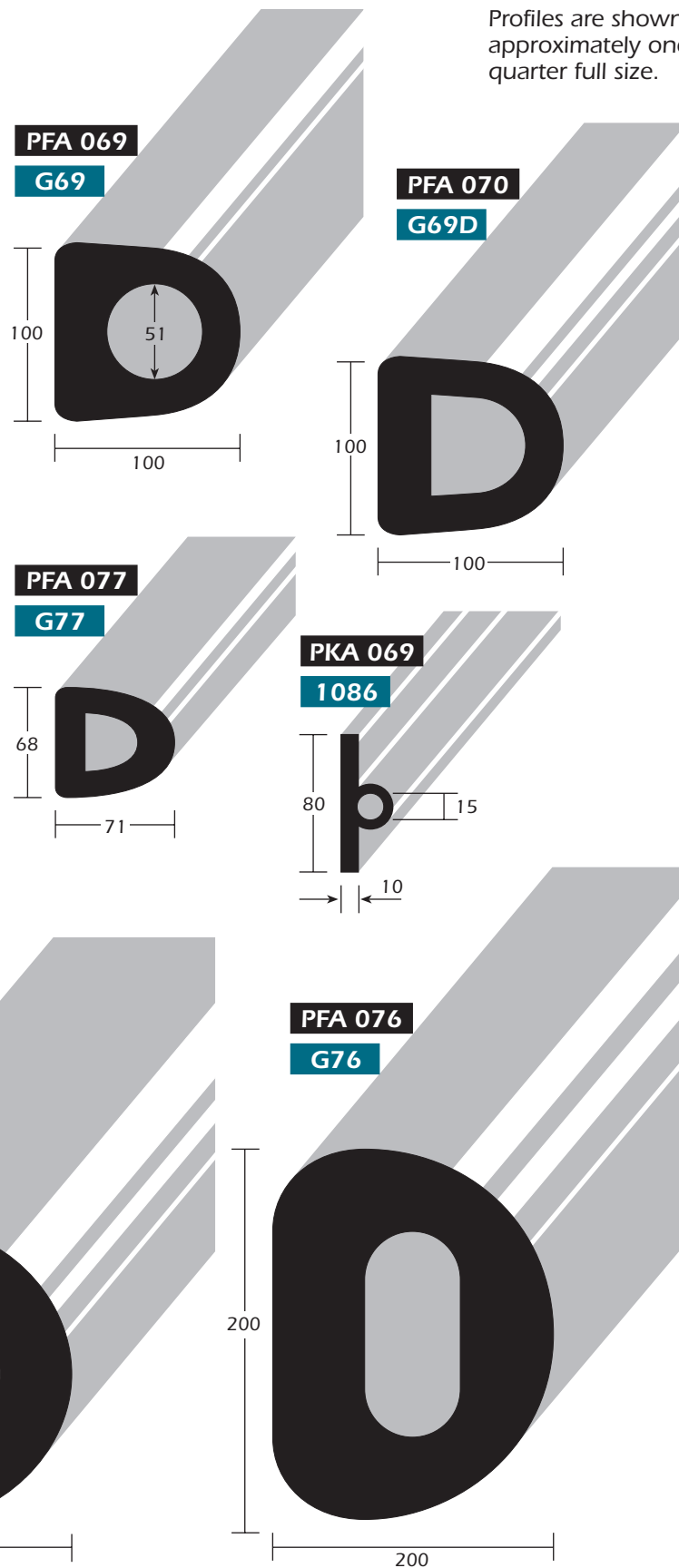

SKELLERUP

NATURAL RUBBER FENDERING SYSTEMS



For Marinas up to Bulk Handling/Container Wharves

For further information contact:



SKELLERUP INDUSTRIAL

A member of the Skellerup Group of Companies

AUCKLAND
80 Alexander Crescent, Otara
PO Box 14-541 Panmure

CHRISTCHURCH
124 Marshall Street, Woolston
Private Bag 4736 Christchurch

Freephone: 0800 4 SKELLERUP (0800 475 355)
Freefax: 0800 4 SKELLFAX (0800 753 553)
Web: www.skellerup.co.nz
Email: info@skellerup.co.nz



MARINA FENDERS

Skellerup manufacture a range of specifically designed rubber extrusions for installation in pleasure and fishing berths. Significant maintenance savings and protection of capital investments can be made through the installation of correct fendering. Manufactured from non-marking (off-white) natural rubber. Easily fixed to pontoons, walkways and jetties.



PFB 038

1038

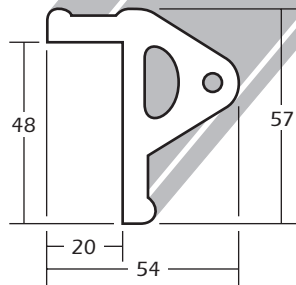

PFB 189

KCV 189

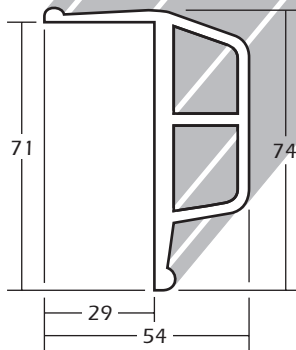

PFB 247

1247

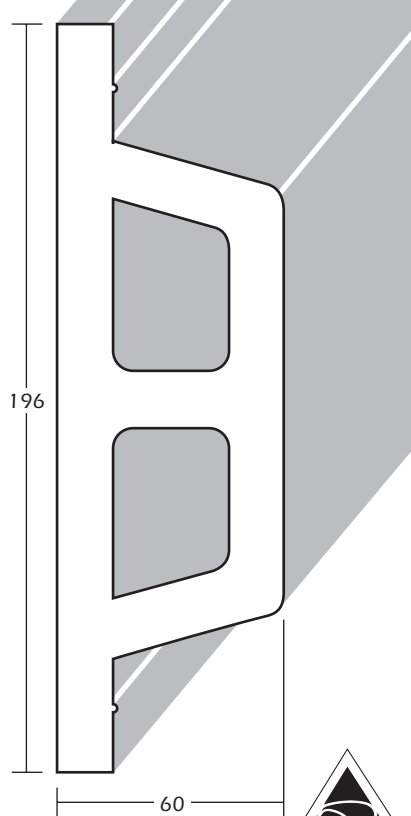

Profiles are shown approximately half full size



UNIT FENDERS

Designed for wharf protection for large displacement vessels; from fishing through to container vessels. Specifically designed for each particular installation, and supplied with all associated wharf anchoring (fixing) hardware; bolts, resin sockets, chains etc. and if required can be fitted with HMWPE front panels. Skellerup are suppliers and distributors of Seibu, Type 11, TTV, V & NW style fenders for wharf or vessel fendering.



H TYPE

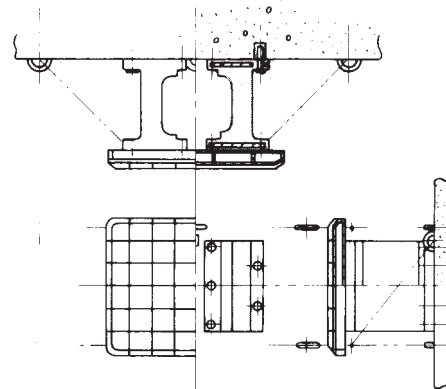

H TYPE

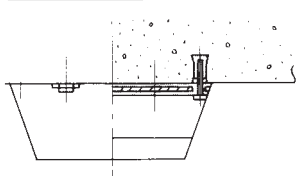

TTV UNIT TYPE

(Commonly called 'UNIT' TYPE)

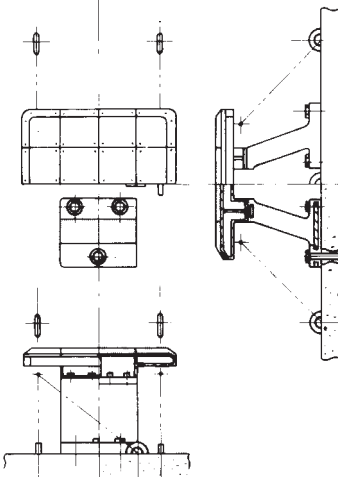

TTV TYPE

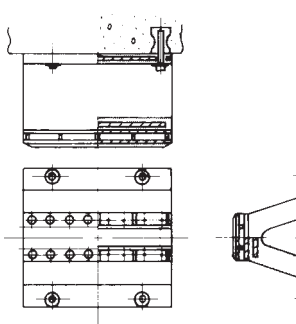

CYLINDRICAL TYPE FENDERS

Proven in the Australasian and Pacific Basin market over the past 30 years, Skellerup Cylindrical Fenders are designed for either axial or radial installation. Available in sizes up to 900mm OD and in lengths to 10 Metres. (OD/ID ratio 2:1).

For axial mounted fenders, mounting spigots are factory fitted in one end and to avoid instability the length is limited to 1.2 times OD.

Manufactured from virgin grade natural rubber, these fenders give excellent protection for both vessel and wharf.

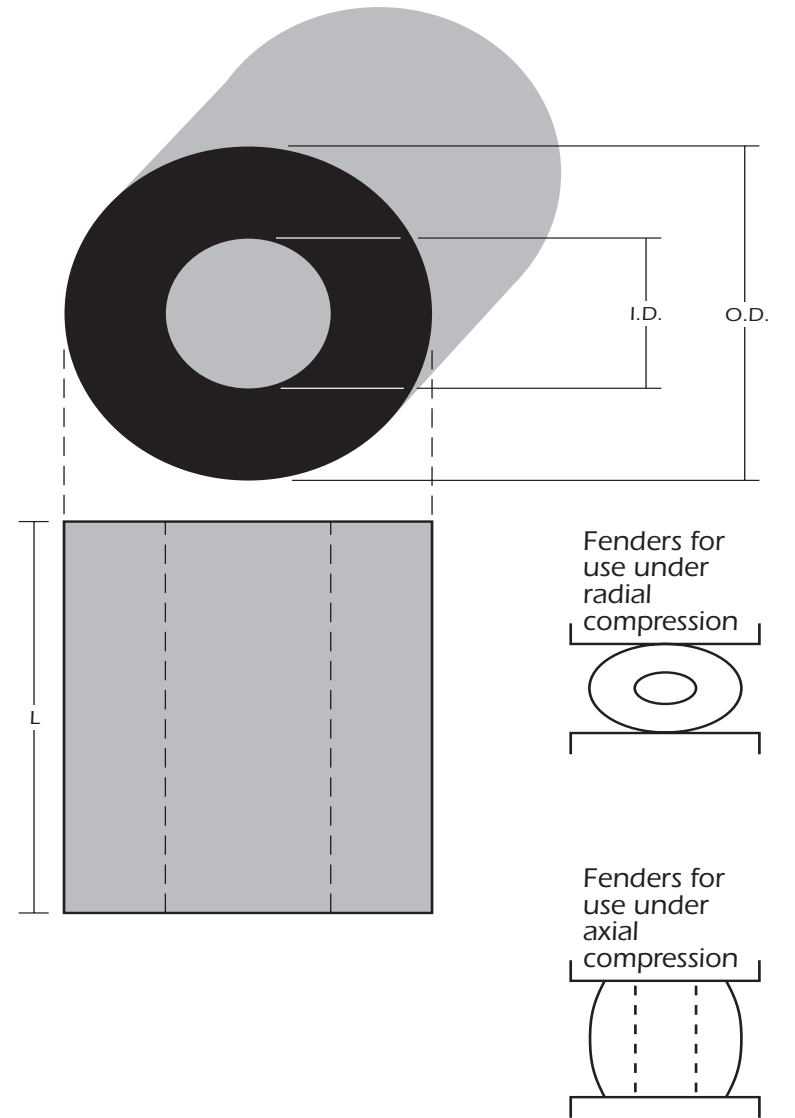

ENERGY ABSORPTION 'E'

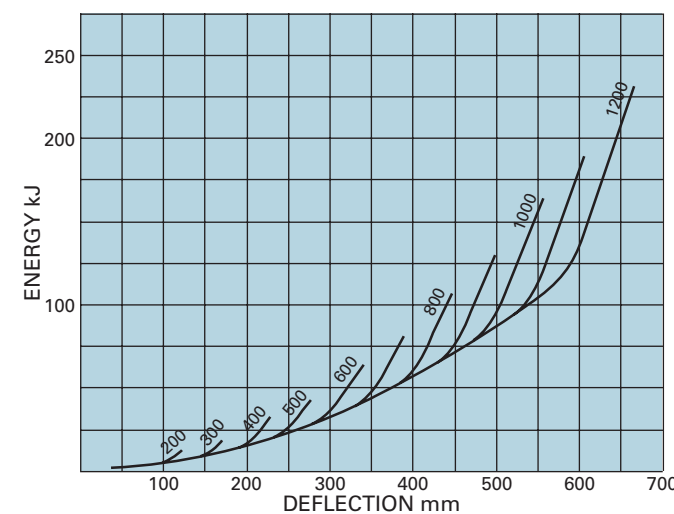

DEFLECTION FORCE 'R'

